

Student Number



Barker College

2014

TRIAL

HIGHER SCHOOL

CERTIFICATE

Mathematics Extension 1

8:30am Thursday 7th August

Staff Involved:

- VAB • BHC
- BJB • ASC
- PJR • GIC*

95 copies

ANSWER SHEET

Section I – Multiple Choice

Choose the best response and clearly mark the circle.

-
- Start →
1. A ○ B ○ C ○ D ○
 2. A ○ B ○ C ○ D ○
 3. A ○ B ○ C ○ D ○
 4. A ○ B ○ C ○ D ○
 5. A ○ B ○ C ○ D ○
 6. A ○ B ○ C ○ D ○
 7. A ○ B ○ C ○ D ○
 8. A ○ B ○ C ○ D ○
 9. A ○ B ○ C ○ D ○
 10. A ○ B ○ C ○ D ○

BLANK PAGE



Barker College

2014 TRIAL HIGHER SCHOOL CERTIFICATE

Mathematics Extension 1

8:30am Thursday 7th August

Staff Involved:

- VAB • BHC
- BJB • ASC
- PJR • GIC*

95 copies

General Instructions

- Reading time – 5 minutes
- Working time – 2 hours
- Write using blue or black pen
- Make sure your Barker Student Number is on ALL pages of your solutions
- Board-approved calculators may be used
- A table of standard integrals is provided at the back of this paper
- ALL necessary working should be shown in every question

Total marks – 70

Section I **Pages 2 - 4**

10 marks

- Attempt Questions 1 – 10
- Allow about 15 minutes for this section

Section II **Pages 6 - 12**

60 marks

- Attempt Questions 11 – 14
- Allow about 1 hour 45 minutes for this section

BLANK PAGE

Section I – Multiple Choice (10 marks)

Attempt Questions 1–10

ALL questions are of equal value

Use the multiple choice answer sheet provided.

1. $\lim_{x \rightarrow 0} \frac{\sin \frac{x}{3}}{\frac{x}{2}}$ is:
- (A) $\frac{2}{3}$ (B) $\frac{1}{6}$ (C) $\frac{3}{2}$ (D) 6
2. The y coordinate of the point which divides the interval AB externally in the ratio 1 : 4 where A is (3, 1) and B is (-1, -5) is:
- (A) $-\frac{1}{3}$ (B) $-\frac{1}{5}$ (C) -1 (D) 3
3. Find $\frac{d}{dx} (1+x^2) \tan^{-1} x$.
- (A) $2x \tan^{-1} x$ (B) $\frac{2x}{1+x^2}$ (C) $\frac{1+x^2}{\sqrt{1-x^2}}$ (D) $1+2x \tan^{-1} x$
4. $\int \frac{dx}{4+9x^2} =$
- (A) $\frac{1}{3} \tan^{-1} \left(\frac{2x}{3} \right)$ (B) $\frac{1}{6} \tan^{-1} \left(\frac{3x}{2} \right)$
- (C) $\frac{1}{6} \tan^{-1} \left(\frac{2x}{3} \right)$ (D) $\frac{1}{3} \tan^{-1} \left(\frac{3x}{2} \right)$
5. Consider the function $f(x) = \frac{3x}{x-1}$ and its inverse function $f^{-1}(x)$.
Evaluate $f^{-1}(2)$.
- (A) 6 (B) -2 (C) 2 (D) -6

6. Find the value of x in this diagram.

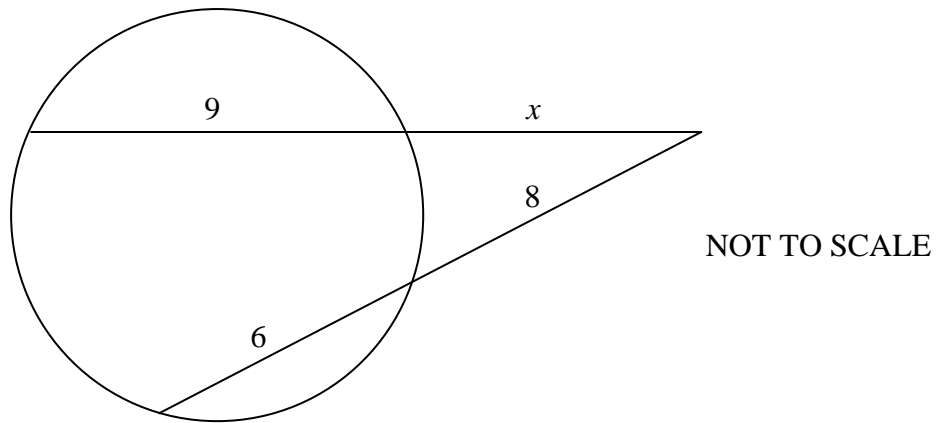

- (A) $x = 16$ (B) $x = 7$ (C) $x = 5$ (D) $x = 10$

- 7.

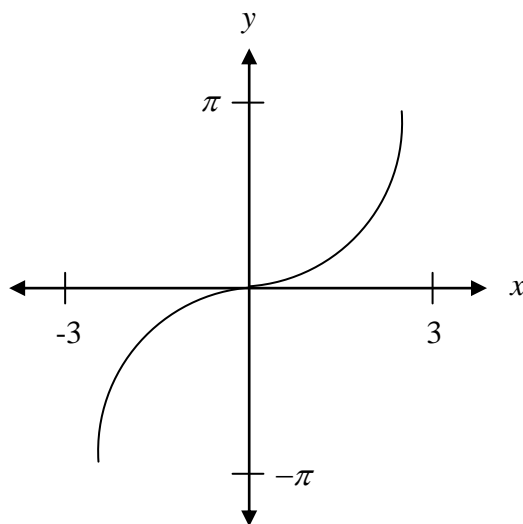

The equation of the curve above is:

- (A) $y = 2\sin^{-1} \frac{x}{3}$ (B) $y = 3\sin^{-1} \frac{x}{2}$
 (C) $y = 2\sin^{-1} 3x$ (D) $y = 3\sin^{-1} 3x$

8. Find the number of ways the letters of the word EPSILON can be arranged in a straight line such that the 3 vowels are all next to each other.

- (A) $7!$ (B) $5!$ (C) $3!5!$ (D) $4!5!$

9. In a raffle there are 50 tickets sold. 6 tickets are especially marked and will win a mystery prize each. Jack buys 3 tickets in the raffle. What is the probability that Jack will win 3 prizes when the first 3 raffle tickets are drawn and not replaced?

(A) $\left(\frac{6}{50}\right)^3$

(B) $\frac{3}{50} \times \frac{2}{49} \times \frac{1}{48}$

(C) $\left(\frac{3}{50}\right)^3$

(D) $\frac{6}{50} \times \frac{5}{49} \times \frac{4}{48}$

10. The velocity of a particle moving in simple harmonic motion in a straight line is given by

$$v^2 = 2 - x - x^2 \text{ ms}^{-1}, \text{ where } x \text{ is displacement in metres.}$$

The centre of motion is:

(A) $x = -2$ (B) $x = 1$ (C) $x = -\frac{1}{2}$ (D) $x = 2$

End of Section I

BLANK PAGE

Section II (60 marks)

Attempt Questions 11 – 14

All questions are of equal value.

Answer each question in a SEPARATE writing booklet. Extra writing booklets are available.

In Questions 11 – 14 show relevant mathematical reasoning and / or calculations.

Question 11 (15 marks)

[Use a SEPARATE writing booklet]

- (a) In how many ways can a committee of 4 men and 7 women be selected from a group of 7 men and 8 women? **2**

- (b) Solve: $\frac{3}{x-4} \geq 1$ **3**

- (c) Evaluate: $\int_0^{2\pi} \sin^2 2x \, dx$. **3**

- (d) Evaluate: $\int_{\frac{1}{2}}^1 4t(2t-1)^5 \, dt$ by using the substitution $u = 2t - 1$. **4**

- (e) For the infinite geometric series:

$$\sin 2x + \sin 2x \cos 2x + \sin 2x \cos^2 2x + \dots \text{ for } 0 < x < \frac{\pi}{2},$$

Show that the limiting sum is $\cot x$. **3**

End of Question 11

Question 12 (15 marks)**[Use a SEPARATE writing booklet]**

- (a) Tap water at 24°C is placed in a fridge-freezer maintained at a temperature of -11°C . After t minutes the rate of change of temperature T of the water is given by

$$\frac{dT}{dt} = -k(T + 11) .$$

- (i) Show that $T = Ae^{-kt} - 11$ is a solution of the above equation, where A is a constant. **1**
- (ii) Find the value of A . **1**
- (iii) After 15 minutes the temperature of the water falls to 10°C . Find, correct to the nearest minute, the time taken for the water to start freezing. (Freezing point of water is 0°C). **2**
- (b) (i) Express $\sqrt{3} \cos \theta - \sin \theta$ in the form $r \cos(\theta + \alpha)$, where $r > 0$ and $0 < \alpha < \frac{\pi}{2}$, giving r and α as exact values. **3**
- (ii) Evaluate the minimum value of the expression $\sqrt{3} \cos \theta - \sin \theta$. **1**

Question 12 (continued)

(c)

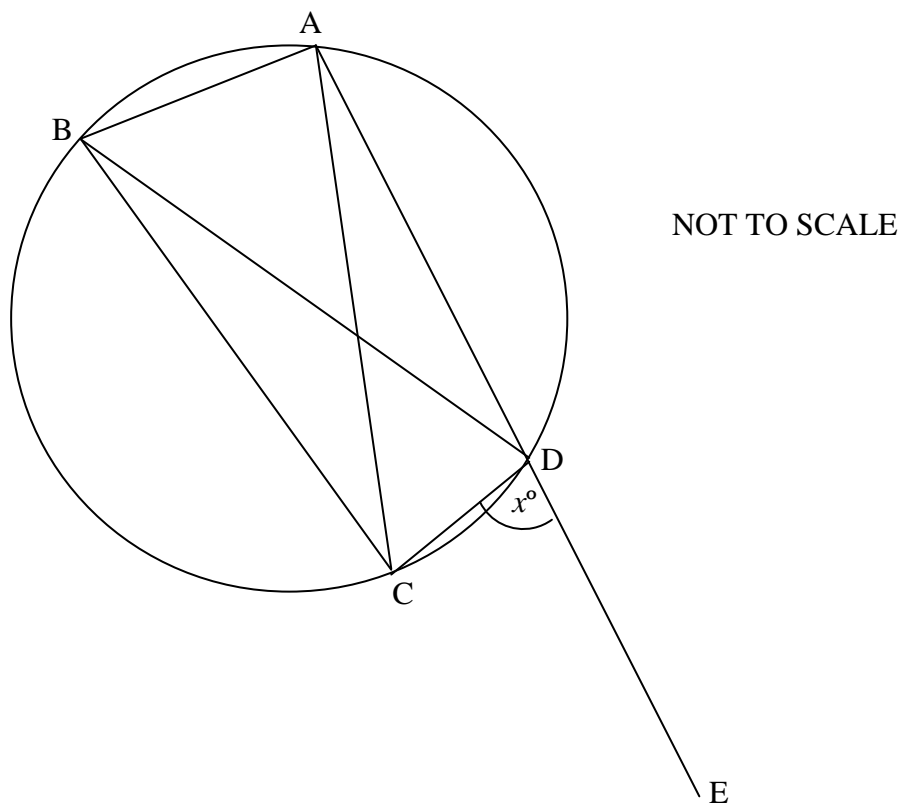

ABC is an isosceles triangle in which $AC = BC$. ABCD is a cyclic quadrilateral. AD is produced to E.

Let $\angle CDE = x^\circ$.

Show that $\angle BDE = 2x^\circ$.

3

(d) For all positive integers n , prove by mathematical induction that:

$$\frac{1}{2!} + \frac{2}{3!} + \frac{3}{4!} + \dots + \frac{n}{(n+1)!} = \frac{(n+1)! - 1}{(n+1)!}$$

4

End of Question 12

(a)

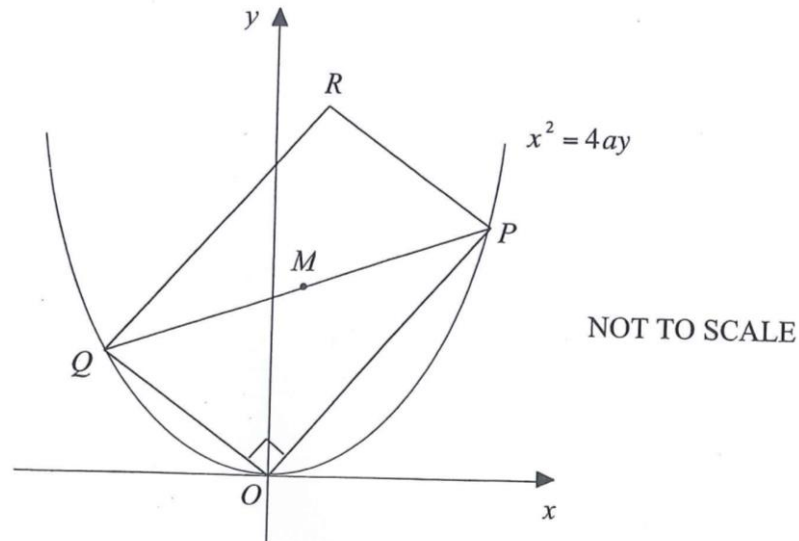

$P(2ap, ap^2)$ and $Q(2aq, aq^2)$ are two points which move on the parabola $x^2 = 4ay$ such that $\angle POQ = 90^\circ$, where $O(0,0)$ is the origin. $M\left(a(p+q), \frac{1}{2}a(p^2+q^2)\right)$ is the midpoint of PQ . R is the point such that $OPRQ$ is a **rectangle**.

- (i) Show that $pq = -4$. 1
- (ii) Show that R has coordinates $(2a(p+q), a(p^2+q^2))$. 1
- (iii) Find the equation of the locus of R . 2

(b) In an experiment, a particle initially at a fixed point O , is moving in a straight line. After time t seconds, it has displacement x metres from O and its velocity $v \text{ ms}^{-1}$ is given by $v = 8 - 2x$.

- (i) Find the acceleration of the particle at the origin. 2
- (ii) Show that $t = -\frac{1}{2} \log_e \left(1 - \frac{x}{4}\right)$. 3
- (iii) Hence, or otherwise, find x as a function of t . 2

Question 13 (continued)

- (c) A plane flying at a height of 2000 m observes a stationary hot air balloon drop an object from a height of 3200 metres. The moment the object is released, the plane fires a projectile at an angle θ to the horizontal in the direction of the object at a velocity of 240 m/s. The horizontal distance between the plane and the hot air balloon is 3.6 km at the time the projectile is fired.

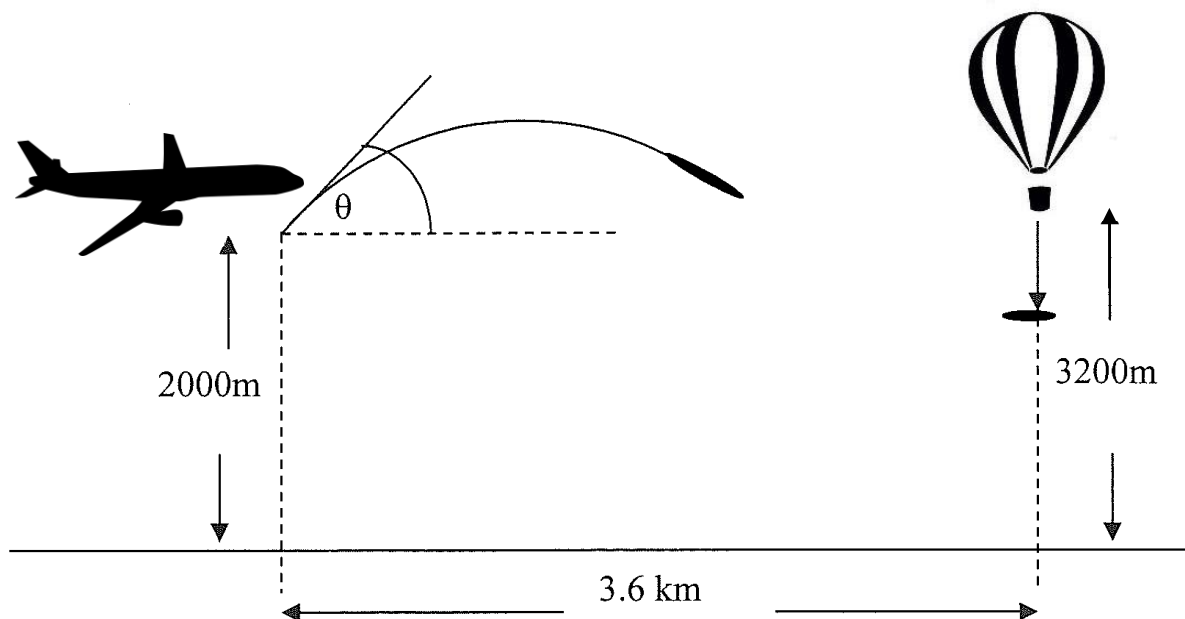

The equations of motion of the projectile fired from the plane are:

$$x = 240t \cos \theta$$

$$y = 2000 + 240t \sin \theta - gt^2$$

The equations of motion of the dropped object (relative to a point below the plane) are:

$$x = 3600$$

$$y = 3200 - gt^2$$

(Do Not Prove These)

(Use $g = 10ms^{-2}$)

- | | | |
|-------|----------------------------------------------------------------------------------------------------------|---|
| (i) | What is the angle (to the nearest minute) at which the projectile must be fired to intercept the object? | 2 |
| (ii) | How long (to the nearest 0.1 second) does it take the projectile to reach the object? | 1 |
| (iii) | At what height does the projectile intercept the object? | 1 |

End of Question 13

(a)

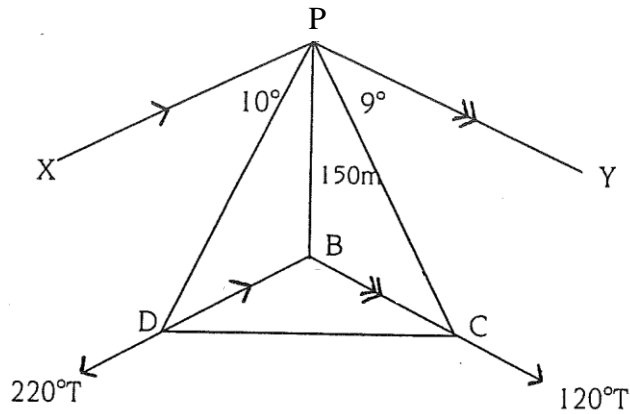

A ship is observed from the top of a 150m cliff BP . When the ship is at point C it has an angle of depression of 9° from the top of the cliff and later at D it has an angle of depression of 10° .

From the cliff the bearing of C is 120°T and D is 220°T .

- (i) Show that $BD = 150 \cot 10^\circ$ 1
- (ii) Hence, or otherwise, show that $CD^2 = 150^2 (\cot^2 10^\circ + \cot^2 9^\circ - 2 \cot 10^\circ \cot 9^\circ \cos 100^\circ)$. 2
- (iii) Find the distance CD . 1

(b) Water is poured into a conical vessel of base radius 20 cm and height 30 cm at a constant rate of 24 cm^3 per second. The depth of water is h cm at time t seconds and V is the volume of the water in the vessel at this time.

- (i) Explain why $r = \frac{2h}{3}$. 1
- (ii) Hence show that the volume of water in the vessel at any time t is given by $V = \frac{4\pi h^3}{27}$. 1
- (iii) Find the rate of increase of the area (A) of the surface of the water, when the depth is 16 cm. 4

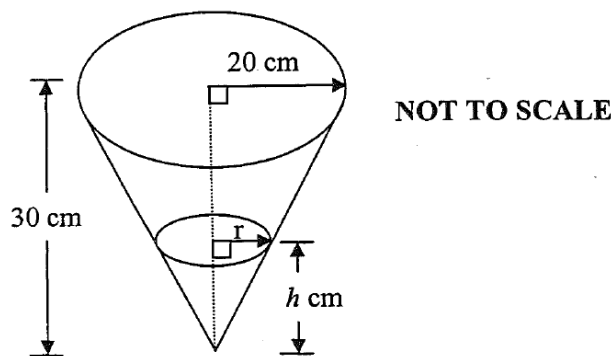

Question 14 (continued)

(c) The rise and fall of the tide is assumed to be simple harmonic. A cruise ship needs 11 metres of water to pass down a channel safely. At low tide the channel is 8 metres deep and at high tide it is 12 metres deep. Low tide is at 10am and high tide is at 4pm.

(i) Show that the water depth, y metres, in the channel is given by

$$y = 10 - 2 \cos\left(\frac{\pi t}{6}\right), \text{ where } t \text{ is the number of hours after low tide.} \quad \mathbf{2}$$

(ii) Find the earliest time period after 10am (i.e. between which two times) that the cruise ship can safely proceed through the channel. **3**

End of Paper

STANDARD INTEGRALS

$$\int x^n dx = \frac{1}{n+1} x^{n+1}, \quad n \neq -1; \quad x \neq 0, \quad \text{if } n < 0$$

$$\int \frac{1}{x} dx = \ln x, \quad x > 0$$

$$\int e^{ax} dx = \frac{1}{a} e^{ax}, \quad a \neq 0$$

$$\int \cos ax dx = \frac{1}{a} \sin ax, \quad a \neq 0$$

$$\int \sin ax dx = -\frac{1}{a} \cos ax, \quad a \neq 0$$

$$\int \sec^2 ax dx = \frac{1}{a} \tan ax, \quad a \neq 0$$

$$\int \sec ax \tan ax dx = \frac{1}{a} \sec ax, \quad a \neq 0$$

$$\int \frac{1}{a^2 + x^2} dx = \frac{1}{a} \tan^{-1} \frac{x}{a}, \quad a \neq 0$$

$$\int \frac{1}{\sqrt{a^2 - x^2}} dx = \sin^{-1} \frac{x}{a}, \quad a > 0, \quad -a < x < a$$

$$\int \frac{1}{\sqrt{x^2 - a^2}} dx = \ln \left(x + \sqrt{x^2 - a^2} \right), \quad x > a > 0$$

$$\int \frac{1}{\sqrt{x^2 + a^2}} dx = \ln \left(x + \sqrt{x^2 + a^2} \right)$$

NOTE: $\ln x = \log_e x$, $x > 0$

Section I – Multiple Choice

$$1. \quad \frac{\sin \frac{x}{3}}{\frac{x}{2}} \times \frac{1}{\frac{1}{2}} = \frac{2}{3} \quad \therefore A$$

$$2. \quad \frac{(1 \times -4) + (-5 \times 1)}{1 + (-4)} = 3 \quad \therefore D$$

$$3. \quad u = 1 + x^2 \quad v = \tan^{-1} x$$

$$u' = 2x \quad v' = \frac{1}{1 + x^2}$$

$$y' = 2x \tan^{-1} x + \frac{1 + x^2}{1 + x^2}$$

$$y' = 2x \tan^{-1} x + 1 \quad \therefore D$$

$$4. \quad \int \frac{dx}{4 + 9x^2} = \frac{1}{9} \int \frac{dx}{\frac{4}{9} + x^2}$$

$$= \frac{1}{9} \times \frac{1}{2/3} \tan^{-1} \left(\frac{x}{2/3} \right) + c$$

$$= \frac{1}{6} \tan^{-1} \left(\frac{3x}{2} \right) + c \quad \therefore B$$

$$5. \quad x = \frac{3y}{y-1}$$

$$xy - x = 3y$$

$$xy - 3y = x$$

$$y(x-3) = x$$

$$y = \frac{x}{x-3}$$

$$f'(2) = \frac{2}{2-3} = -2 \quad \therefore B$$

$$6. \quad x(x+9) = 14 \times 8$$

$$x^2 + 9x - 112 = 0$$

$$(x+16)(x-7) = 0$$

$$\therefore x = -16, 7 \quad (x > 0)$$

$$\therefore x = 7 \quad \therefore B$$

$$7. \quad y = 2 \sin^{-1} \left(\frac{x}{3} \right) \quad \therefore A$$

$$8. \quad 3! \times 5! \quad \therefore C$$

$$9. \quad \frac{3}{50} \times \frac{2}{49} \times \frac{1}{48} \quad \therefore B$$

$$10. \quad v^2 = x^2 + x - 2 = 0$$

$$(x+2)(x-1) = 0$$

$$\therefore x = -2, 1 \quad \therefore \text{centre} = -\frac{1}{2} \quad \therefore C$$

Question 11

$$a) \quad {}^7C_4 \times {}^8C_7 = 280$$

$$b) \quad \frac{3}{x-4} \times (x-4)^2 \geq 1(x-4)^2$$

$$3(x-4) \geq (x-4)^2$$

$$(x-4)^2 - 3(x-4) \leq 0$$

$$(x-4)[(x-4)-3] \leq 0$$

$$(x-4)(x-7) \leq 0$$

$$\therefore 4 < x \leq 7$$

$$c) \quad \cos 2x = 1 - 2 \sin^2 x$$

$$\rightarrow \sin^2 x = \frac{1}{2}(1 - \cos 2x)$$

$$\int_0^{2\pi} \sin^2 2x \, dx = \frac{1}{2} \int_0^{2\pi} (1 - \cos 4x) \, dx$$

$$= \frac{1}{2} \left[x - \frac{1}{4} \sin 4x \right]_0^{2\pi}$$

$$= \frac{1}{2} [(2\pi - 0) - (0 - 0)]$$

$$= \pi$$

$$d) \quad u = 2t - 1 \quad \text{when } t = \frac{1}{2}, u = 0$$

$$\frac{du}{dt} = 2 \quad t = 1, u = 1$$

$$dt = \frac{du}{2} \quad 2t = u + 1$$

$$4t = 2(u + 1)$$

$$\int_{\frac{1}{2}}^1 4t(2t-1)^5 \, dt = \int_0^1 2(u+1) \times u^5 \times \frac{du}{2}$$

$$= \int_0^1 u^6 + u^5 \, du$$

$$= \left[\frac{u^7}{7} + \frac{u^6}{6} \right]_0^1$$

$$= \left(\frac{1}{7} + \frac{1}{6} \right) - (0 - 0)$$

$$= \frac{13}{42}$$

14

$$S = \frac{\sin 2x}{1 - \cos 2x}$$

$$= \frac{2 \sin x \cos x}{1 - (1 - 2 \sin^2 x)}$$

$$= \frac{2 \sin x \cos x}{2 \sin^2 x}$$

$$= \frac{\cos x}{\sin x}$$

$$= \cot x$$

Question 12

$$a) \quad (i) \quad \frac{dT}{dt} = -kAe^{-kt}$$

$$Ae^{-kt} = T + 11$$

$$\therefore \frac{dT}{dt} = -k(T + 11)$$

\therefore a solution

$$(ii) \quad \text{when } t = 0, T = 24$$

$$24 = Ae^0 - 11$$

$$A = 35$$

$$(iii) \quad \text{when } t = 0, T = 24$$

$$10 = 35e^{-15k} - 11$$

$$\frac{21}{35} = e^{-15k}$$

$$\ln \left(\frac{3}{5} \right) = -15k$$

$$k = \frac{-1}{15} \ln \left(\frac{3}{5} \right)$$

when $T = 0$

$$0 = 35e^{-kt} - 11$$

$$\frac{11}{35} = e^{-kt}$$

$$-kt = \ln \left(\frac{11}{35} \right)$$

$$t = \frac{\ln \left(\frac{11}{35} \right)}{-k} = 34 \text{ min}$$

b) (i)

$$\sqrt{3} \cos \theta - \sin \theta = r \cos(\theta + \alpha)$$

$$= r \cos \theta \cos \alpha - r \sin \theta \sin \alpha$$

$$\therefore \sqrt{3} = r \cos \alpha \quad 1 = r \sin \alpha$$

$$\cos \alpha = \frac{\sqrt{3}}{r} \quad \sin \alpha = \frac{1}{r}$$

$$\therefore r = 2 \quad \alpha = \frac{\pi}{6}$$

$$\therefore \sqrt{3} \cos \theta - \sin \theta = 2 \cos(\theta + \pi/6)$$

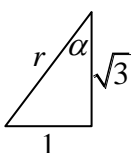

(ii) minimum value -2

c) (i) $\angle CDE = x^\circ = \angle ABC$

(ext \angle of cyclic quad = opp int \angle)

(ii) $\angle BAC = x^\circ$ (base \angle of isos Δ =)

$\angle BDC = \angle BAC = x^\circ$ (\angle 's in same segment)

$$\begin{aligned} \therefore \angle BDE &= x^\circ + x^\circ \text{ (adj } \angle\text{'s)} \\ &= 2x^\circ \end{aligned}$$

d) Prove true for $n = 1$

$$\text{LHS} = \frac{1}{2!} = \frac{1}{2}$$

$$\text{RHS} = \frac{2!-1}{2!} = \frac{1}{2}$$

$\therefore \text{LHS} = \text{RHS}$, \therefore true for $n = 1$

Assume true for $n = k$

$$\therefore \frac{1}{2!} + \dots + \frac{k}{(k+1)!} = \frac{(k+1)!-1}{(k+1)!}$$

Prove true for $n = k + 1$

$$\text{RTP: } \frac{1}{2!} + \dots + \frac{k}{(k+1)!} + \frac{k+1}{(k+2)!} = \frac{(k+2)!-1}{(k+2)!}$$

$$\text{LHS} = \frac{(k+1)!-1}{(k+1)!} + \frac{k+1}{(k+2)(k+1)!}$$

$$= \frac{(k+2)((k+1)!-1) + k+1}{(k+2)(k+1)!}$$

$$= \frac{(k+2)!-k-2+k+1}{(k+2)(k+1)!}$$

$$= \frac{(k+2)!-1}{(k+2)!}$$

$$= \text{RHS}$$

\therefore statement true for $n = 1, k, k + 1$

\therefore true for all +ve integers n

Question 13

a) (i) $m_{op} \times m_{oq} = -1$

$$\frac{ap^2}{2ap} \times \frac{aq^2}{2aq} = -1$$

$$\frac{p}{2} \times \frac{q}{2} = -1$$

$$\therefore pq = -4$$

(ii) M is midpt of OR and O(0,0)

$$\therefore \mathbf{R} = \left(2 \times a(p+q), 2 \times \frac{1}{2} a(p^2 + q^2) \right)$$

$$= (2a(p+q), a(p^2 + q^2))$$

(iii) $x = 2a(p+q)$

$$\therefore p+q = \frac{x}{2a}$$

$$y = a(p^2 + q^2) = a[(p+q)^2 - 2pq]$$

$$= a \times \left[\frac{x^2}{4a^2} - 2 \times -4 \right]$$

$$y = \frac{x^2}{4a} + 8a$$

(b) (i) $\frac{1}{2}v^2 = \frac{1}{2}(8-2x)^2$

$$\begin{aligned} \therefore \ddot{x} &= \frac{d}{dx} \left(\frac{1}{2}v^2 \right) = \frac{2}{2}(8-2x) \times -2 \\ &= -2(8-2x) \end{aligned}$$

when $x = 0, \ddot{x} = -16$

$$(ii) \frac{dx}{dt} = 8-2x \quad \therefore \frac{dt}{dx} = \frac{1}{8-2x}$$

$$t = -\frac{1}{2} \int \frac{-2}{8-2x} dx$$

$$t = -\frac{1}{2} \ln(8-2x) + c$$

when $t = 0, x = 0$

$$\therefore 0 = -\frac{1}{2} \ln 8 + c$$

$$c = \frac{1}{2} \ln 8$$

$$t = -\frac{1}{2} \ln(8-2x) + \frac{1}{2} \ln 8$$

$$= -\frac{1}{2} [\ln(8-2x) - \ln 8]$$

$$= -\frac{1}{2} \ln \left(\frac{8-2x}{8} \right)$$

$$= -\frac{1}{2} \ln \left(1 - \frac{x}{4} \right)$$

(iii) $-2t = \ln \left(1 - \frac{x}{4} \right)$

$$e^{-2t} = 1 - \frac{x}{4}$$

$$\frac{x}{4} = 1 - e^{-2t}$$

$$x = 4 - 4e^{-2t}$$

c) (i) $3600 = 240t \cos \theta$

$$\therefore t = \frac{15}{\cos \theta}$$

$$3200 - gt^2 = 2000 + 240 \left(\frac{15}{\cos \theta} \right) \sin \theta - gt^2$$

$$1200 = 3600 \tan \theta$$

$$\tan \theta = \frac{1}{3}$$

$$\theta = 18^\circ 26'$$

$$(ii) t = \frac{15}{\cos 18^\circ 26'}$$

$$= 15.8 \text{ sec}$$

$$(iii) y = 3200 - 10 \times 15.8^2$$

$$\approx 700 \text{ m}$$

Question 14

a) (i) $\angle PDB = 10^\circ$ (alternate \angle 's)

$$\tan 10^\circ = \frac{150}{BD}$$

$$BD = \frac{150}{\tan 10^\circ}$$

$$BD = 150 \cot 10^\circ$$

(ii)

$$CD^2 = (150 \cot 10^\circ)^2 + (150 \cot 9^\circ)^2 - 2 \times$$

$$150 \cot 10^\circ \times 150 \cot 9^\circ \times \cos 100^\circ$$

$$= 1900407$$

$$\approx 1379 \text{ m}$$

b) (i)

$8 \rightarrow 12 \therefore$ centre of motion is 10m

\therefore amplitude is 2

10am \rightarrow 4pm = 6hrs = $\frac{1}{2}$ of period

$$\therefore 2 \times 6 = \frac{2\pi}{n} \quad \therefore n = \frac{\pi}{6}$$

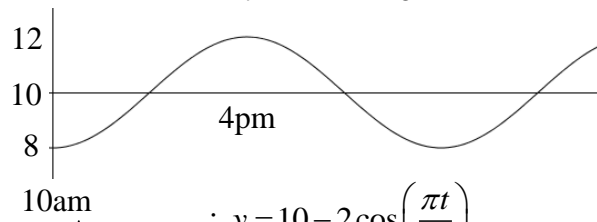

$$\therefore y = 10 - 2 \cos \left(\frac{\pi t}{6} \right)$$

(ii) $11 = 10 - 2 \cos \left(\frac{\pi t}{6} \right)$

$$-\frac{1}{2} = \cos \left(\frac{\pi t}{6} \right)$$

$$\therefore \frac{\pi t}{6} = \frac{2\pi}{3}, \frac{4\pi}{3}$$

$$t = \frac{12\pi}{3\pi}, \frac{24\pi}{3\pi}$$

$$= 4, 8$$

\therefore 10am + 4 = 2pm

10am + 8 = 6pm

\therefore between 2pm and 6pm

$$\text{c)(i)} \frac{r}{20} = \frac{h}{30} \text{ (similar } \Delta\text{'s)}$$

$$r = \frac{2h}{3}$$

$$\text{(ii)} V = \frac{1}{3} \pi r^2 h$$

$$\therefore V = \frac{1}{3} \pi \times \left(\frac{2h}{3}\right)^2 \times h$$

$$V = \frac{4\pi h^3}{27}$$

$$\text{(iii)} A = \pi r^2 \qquad \frac{dV}{dh} = \frac{4\pi h^2}{9}$$

$$A = \pi \left(\frac{2h}{3}\right)^2 \qquad \frac{dh}{dt} = \frac{dh}{dV} \times \frac{dV}{dt}$$
$$= \frac{4\pi h^2}{9} \qquad = \frac{9}{4\pi h^2} \times 24$$

$$\therefore \frac{dA}{dh} = \frac{8\pi h}{9} \qquad \frac{dh}{dt} = \frac{54}{\pi h^2}$$

$$\therefore \frac{dA}{dt} = \frac{dA}{dh} \times \frac{dh}{dt}$$
$$= \frac{8\pi h}{9} \times \frac{54}{\pi h^2}$$
$$= \frac{48}{h}$$

when $h = 16\text{cm}$

$$\frac{dA}{dt} = 3\text{cm}^2 / \text{s}$$